

OPERATION MANUAL



ELITE INDUSTRIAL SALES



FACING MACHINE TSM-1501M

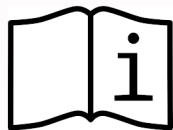

01.2017

SERIAL # _____

For General Questions / Sales / Service
Phone Number: 916-573-7800 or 916-826-5542
www.eliteindustrialsales.com

TABLE OF CONTENTS

1.	INTRODUCTION	2
2.	SAFETY PRECAUTIONS	3
3.	DESCRIPTION	4
4.	SET-UP AND OPERATION / TUBE AND PIPE COLLET CHART	5
5.	ELECTRIC DRILL MOTOR	6
6.	TOOL BIT SELECTION / CHART	7
7.	FEED HANDLE	8
8.	FEED DIAL INDICATOR.....	8
9.	OVERVIEW OF OPERATIONS.....	9
10.	MAINTENANCE.....	10
11.	WARRANTY.....	11
12.	EXPLODED VIEW & PARTS LIST.....	12

1. INTRODUCTION

Warning:

Elite Industrial Sales is committed to continued product improvement therefore; the machine you received may be slightly different than the one described herein. This manual and the information provided is a basic guide line for our customers. Elite Industrial Sales will do its best to ensure that the information and procedures contained in this manual are correct and up-to-date. However, Elite Industrial Sales cannot guarantee that it is correct for all applications or situations. Furthermore, the contents of this manual are subject to change without notice. It is, therefore, the obligation of the user to read all information in this manual, become familiar with the equipment to be used, and exercise the utmost care in equipment operation. Do not make any modifications to this equipment since this will void all warranty claims, as well as possibly increasing the risk of injury or harm. Also, do not operate this equipment if all parts are not functioning at 100% efficiency. Notify us immediately for any needed repairs.

Note: Elite Industrial Sales can supply all repair and replacement parts necessary for maintenance and operation of this machine. For repair, service or additional information, please contact us:

USA

Elite Industrial Sales (Corporate/Sales/Mfg. Division)

For General Questions / Sales / Service

Phone Number: 916-573-7800 or 916-826-5542

www.eliteindustrialsales.com

When you receive it:

Inspect the machine for shipping damage. Be sure you received the parts listed on the invoice. Contact Elite Industrial Sales immediately if there are any errors or questions regarding this machine.

2. SAFETY PRECAUTIONS

The following is a list of general safety guidelines to be considered when operating this tool. Standard safe machining practices should always be followed when operating ELITE INDUSTRIAL SALES Machines.

Before operating this machine, read the entire Operating Instructions. Inspect machine, cord and accessories for any damage.

Wear Safety glasses, ear plugs, and safety shoes while operating the machine. Keep your equipment clean and in good condition for maximum protection. Follow company and OSHA safety rules when operating equipment.

The motor should always be disconnected from the power source whenever servicing the machine or changing cutting inserts, collets, or other components.

SAFETY INFORMATION

WARNING!

MOVING PARTS. Keep hands, loose clothing, and hair away from rotating or moving parts. Unplug all equipment prior to adjusting or servicing.

WARNING!

ELECTRICAL SHOCK. Possible shock if not handled properly.

WARNING!

KEEP DRY. Keep all equipment and components away from any water source.

WARNING!

EYE PROTECTION. Eye protection must be worn while operating or working near facing equipment.

WARNING!

EAR PROTECTION. Ear protection should be worn while operating or working near loud equipment.

3. DESCRIPTION

The TSM-1501M Tube Squaring Machine is designed for facing short tubing and elbows from 1/8" to 1" diameter and piping from 1/4" to 3/4" with lengths greater than .20". This machine is portable or may be mounted on a bench for high volume operations.

We also offer two collets: our standard collets for facing micro fitting or short tubing from .20" long and our extended collets for 1" and above. The collets are made from hard Stainless Steel and are designed so the integrity of electro-polished tubing is not affected by their use. Our tool bits are designed to work on the following materials: stainless steel, inconel, hastelloy, carbon steels, aluminum, and a variety of other alloys.

This machine will let you face quickly and squarely every time. You will also find this machine has an unobstructed view of the tool bit and tubing. Our feed indicator will give you precise length every time.

The Standard TSM-1501M-10 Package Includes:

- Operating tool (main body)
- Head Assembly
- Electric drive unit
- Custom carrying case
- Two facing tool bits
- Tool kit
- Operating manual

Optional Features:

- Bench mounting hold down kit
- Battery power motor

Specifications:

- Weight (with motor, without collets): 9 lbs. (3.6 kg)
- Overall length: 15 inches (381. mm)
- Overall height: 8 inches (203 mm)
- Motor: 120VAC 60Hz-US style
220VAC 50 Hz-CE Compliant

4. SET UP AND OPERATION

COLLET SET UP:

1. Unscrew latch on head assembly on facing machine. You will need to back out the screw on the top of the head before unscrewing the screw on outer latch.
2. Take lower half collet (with 2 springs attached) that fits the size of tubing or pipe and insert into assembly head. Now take the upper half of the collet and insert into head.



Collet Sizes:

Standard

Part Number	Description (Inches / mm)
M1-001	1/8" TUBE COLLET
M1-002	1/4" TUBE COLLET
M1-003	3/8" TUBE COLLET
M1-004	1/2" TUBE COLLET
M1-005	5/8" TUBE COLLET
M1-006	3/4" TUBE COLLET
M1-008	7/8" TUBE COLLET
M1-007	1" TUBE COLLET / 25.4mm

Extended

Part Number	Description (Inches / mm)
M2-030	1/8" TUBE COLLET
M2-031	1/4" TUBE COLLET
M2-032	3/8" TUBE COLLET
M2-033	1/2" TUBE COLLET
M2-034	5/8" TUBE COLLET
M2-035	3/4" TUBE COLLET
M2-038	7/8" TUBE COLLET
M2-036	1" TUBE COLLET / 25.4mm

Part Number Description (Millimeters)

Part Number	Description (Millimeters)
M1-011	6mm TUBE COLLET
M1-013	8mm TUBE COLLET
M1-014	10mm TUBE COLLET
M1-015	12mm TUBE COLLET
M1-017	14mm TUBE COLLET
M1-018	15mm TUBE COLLET
M1-019	18mm TUBE COLLET
M1-020	22mm TUBE COLLET

Part Number Description (Millimeters)

Part Number	Description (Millimeters)
M2-039	6mm TUBE COLLET
M2-040	8mm TUBE COLLET
M2-041	10mm TUBE COLLET
M2-042	12mm TUBE COLLET
M2-043	14mm TUBE COLLET
M2-044	15mm TUBE COLLET
M2-045	18mm TUBE COLLET
M2-046	22mm TUBE COLLET

(Please note: some millimeter sizes are also equivalent to standard US standards)
 Looking for a special size collet? Contact our sales department for pricing and delivery time.

5. ELECTRIC DRILL MOTOR

The electric motor can be rotated 360 degrees to allow for comfortable machine operation.

TO ROTATE MACHINE:

1. Loosen the socket head cap screw on the split collar.
2. Rotate the motor to the most comfortable and or convenient position.
3. Tighten the socket head cap screw before turning on the machine.

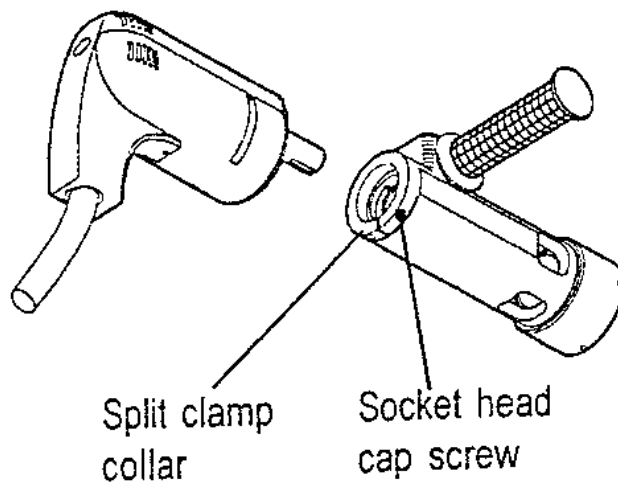

6. TOOL BIT SELECTION

Select the right tool bit for your application. **Note: using the wrong type of tool bit or using dull bits may result in poor performance.**

Remember that these tool bits are design to move the chip away from the tubing; this is done by the angle of the tool bit which helps the chips flow away from the tubing by the radius angle built into the tool bit. It is important to understand the design of the tool bit; you want to set the cutting bit closest to the inside of the tool bit as possible. This will give you the best cutting edge on the tool bit.

TO CHANGE BITS:

1. Unplug the motor from the power source before installing the tool bits.
2. Insert the tool bit into the slot and align the tool bit to the size of tubing or piping to the marking on the cutter head. This will give you a starting point.
3. Make sure the cutting edge is facing "Counter clockwise" and set screws are facing away from cutting edge.
4. Tighten down the set screws.

TOOL BIT SELECTION FOR TSM-1501M:

Part Number	Description
TB-0202	Extended reach standard style
TB-0202-LC	Extended reach laser coated
TB-1506	For use on 316 or 304 stainless steel
TB-1506-LC	Laser coated for abrasion resistance
TB-1506-TIN	Tin coated for superior heat resistance
TB-5000	For soft and gummy stainless steel tubing
TB-0204	Heavy duty for larger wall thicknesses
TB-1510	Double sided tool insert (carbide)
TSM-AD-1500	Tool bit adapter/holder for inserts

(Tool bits can be requested with TIN or Laser coating)

Tool Bits are designed to keep chips out of polished ID Tubing. Our laser coated tool bits will give twice the life of standard bits. Note: We recommend using Extended Collets if tubing is longer than 2".

NOTE:

Slower speeds produce minimum burrs when working with electro polished stainless tubing.

CAUTION!

Running the drill too fast will harden the stainless-steel tubing and quickly damage the tool bits.

7. FEED HANDLE & FEED DIAL INDICATOR

For the comfort and convenience of the operator, or if you have constraints within the work area, the feed handle can be changed from one side of the main body to the other. The feed handle has an index and an index pointer that is used to accurately feed the tool bit into the work piece. The index is calibrated in .015" markings.

TO CHANGE THE FEED HANDLE MOUNTING:

1. Remove the four socket head cap screws.
2. Remove the entire handle assembly and position it to the desired locations (on the right or left side of the main body).
3. Replace the four socket head cap screws and tighten securely.

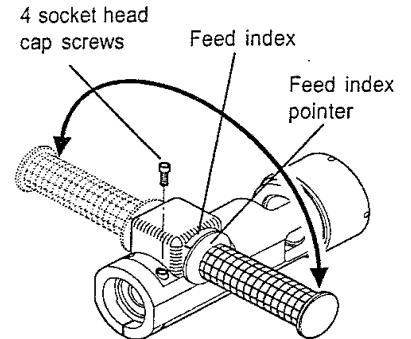

The cover and handle are moved as one piece. Remove cap screws and reposition assembly 180°.

FEED DIAL INDICATOR:

The feed dial indicator is only used when a certain amount of travel is needed. Typically, just giving the tube end a 100% clean up is enough.

TO USE FEED DIAL INDICATOR:

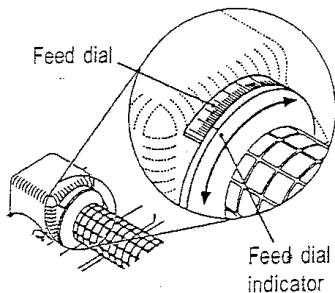

1. With the motor off, use the feed handle to advance the tool bit forward just until it contacts the work piece.
2. Holding the cutter against the work piece, rotate feed dial indicator to any reference mark on the feed dial. The feed dial is stamped in .015" increments.
3. Back the tool bit away from the work piece.
4. Start the motor and feed as before using the referenced feed dial setting as a depth of cut guide.

8. OVERVIEW OF OPERATIONS

1. Install collet per Section 4 "Set-Up and Operation"
2. Put tubing or pipe into collet and adjust tubing to leave $\frac{1}{4}$ " gap between cutting bit (tool bit) and tubing. Tighten down cap "Clockwise" See picture below.

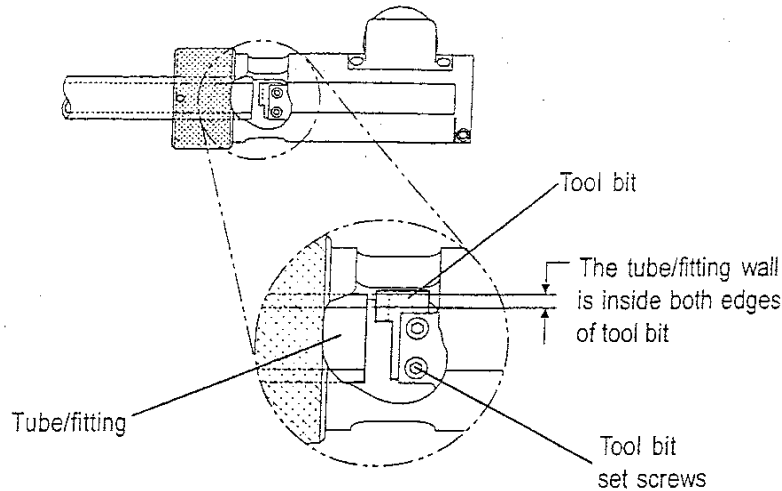

3. Adjust tool bit per Section 6 "Tool Bit Selection". See above picture.
4. Plug in motor, and put safety glasses on.
5. Sit dial indicator per Section 7 "Feed Dial Indicator".
6. Turn motor in "Clockwise" direction and feed tubing or pipe by turning the handle into the tubing. **"Remember"** you want to have the motor turning at a low speed so that the tool bit does not lock into the tubing or pipe when cutting stainless steel.
7. Make your pass around the tool bit with the tool bit and as soon as you take a full rotation around the tubing and pipe and take a full cut, you have now completed a square end. You would only want to take more off the tubing if you need to bring to a certain size length.
8. When you have finish facing the tubing or pipe, un-screw the cap and release the collet around the tube or pipe.

The Elite Industrial Sales TSM-1501M Facing/Squaring Machine will last for many years with proper care and maintenance. Keep your equipment clean and perform proper maintenance for superior performance and a long life cycle.

9. MAINTENANCE

GENERAL MACHINE MAINTENANCE

During heavy operation, regularly use a brush to clean chips away from the machine. Wipe the machine down thoroughly when you are through with the machine. Do not spray anything into the electric motor body.

ELECTRIC MOTOR MAINTENANCE

Periodically check the motor brushes for excess wear or damage. Replace as needed. Check the power cord for cuts, tears, or abrasions.

COLLET MAINTENANCE

Keep clamp collets together in their respective sets. When not in use, store in case. Collet repair kits are available from your retailer.

TOOL BIT MAINTENANCE

When possible, leave unused tool bits in their packages to prevent them from being damaged. Please store tool bits that have been taken from their original package in a safe place.

10. WARRANTY

EVERY ELITE INDUSTRIAL SALES MACHINE IS THOROUGHLY INSPECTED AND TESTED BEFORE LEAVING OUR MANUFACTURING FACILITIES. ALL PRODUCTS MANUFACTURED BY ELITE INDUSTRIAL SALES SYSTEMS, INC. ARE WARRANTED TO THE ORIGINAL PURCHASER TO BE FREE FROM DEFECTS IN MATERIAL AND WORKMANSHIP. UNDER NORMAL USE, THE MACHINE IS WARRANTED FOR A PERIOD OF ONE YEAR FROM THE DATE OF PURCHASE. THIS DOES NOT INCLUDE TOOL BITS OR OTHER CONSUMABLE ITEMS. SHOULD ANY TROUBLES OR CONCERNS DEVELOP, RETURN THE COMPLETE TOOL PREPAID TO ELITE INDUSTRIAL SALES SYSTEMS, INC. OR TO THE NEAREST AUTHORIZED SERVICE CENTER. IF INSPECTION SHOWS THE TROUBLE IS CAUSED BY DEFECTIVE WORKMANSHIP OR MATERIAL, ELITE INDUSTRIAL SALES AT ITS OPTION WILL REPAIR OR REPLACE WITHOUT CHARGE FOR EITHER PARTS OR LABOR. THE PRODUCT WILL BE RETURNED TO THE PURCHASER FREIGHT PREPAID AND BILLED TO THE PURCHASER.

WARRANTY IS TWELVE MONTHS (12MO) 1 YEAR WARRANTY FROM DATE OF PURCHASE. PLEASE REVIEW BELOW INFORMATION REGARDING THE WARRANTY DETAILS. THIS DOES NOT INCLUDE TOOL BITS OR OTHER CONSUMABLE ITEMS.

WARRANTY DOES NOT APPLY IF:

- 1) REPAIRS OR ATTEMPTED REPAIRS HAVE BEEN MADE BY PERSONS OTHER THAN ELITE INDUSTRIAL SALES PERSONAL, OR UNAUTHORIZED SERVICE REPAIR PERSONNEL.
- 2) REPAIRS ARE REQUIRED BECAUSE OF NORMAL WEAR.
- 3) THE TOOL HAS BEEN ABUSED OR INVOLVED IN AN ACCIDENT.
- 4) MISUSE IS EVIDENT, SUCH AS OVERLOADING THE TOOL BEYOND ITS RATED CAPACITY. THE TOOL HAS BEEN USED AFTER PARTIAL FAILURE, OR THE TOOL HAS BEEN USED WITH AN IMPROPER ACCESSORIES.
- 5) THE MOTOR IS DAMAGED DUE TO NOT USING OILER/MISTER WHILE USING (PENDING MOTOR TYPE).

NO OTHER WARRANTY VALID IF EITHER WRITTEN OR VERBALLY IS AUTHORIZED.

11. TSM-1501M EXPLODED VIEWS AND PARTS LIST

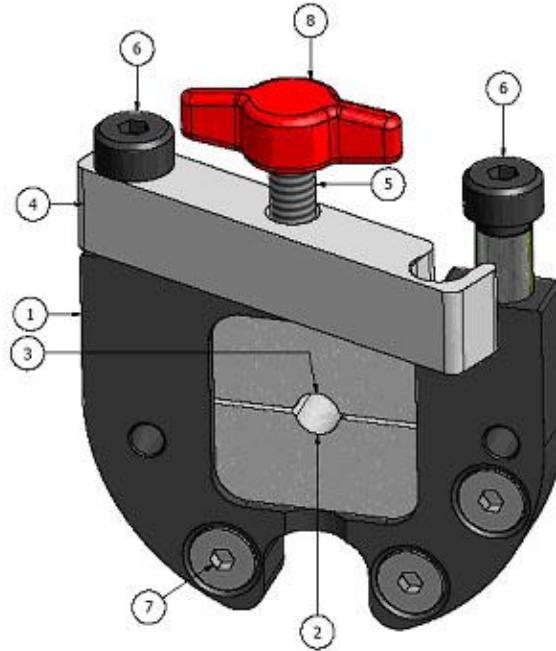

Parts List			
ITEM	QTY	PART NUMBER	DESCRIPTION
1	1	TSM-293	1500M1 CLAMP BODY
2	1	LOWER COLLET	SEE TABLES FOR PART NUMBERS
3	1	UPPER COLLET	SEE TABLES FOR PART NUMBERS
4	1	TSM-291	RAIL CLAMP
5	1	SHCS-English-UNC	1/4-20 X 3/4" SOCKET HEAD CAP SCREW
6	2	ShoulderBolt	5/16" X 1/2" SOCKET HEAD SHOULDER BOLT
7	3	FHMS-English-UNF	10-32 X 3/4" FLAT HEAD CAP SCREW
8	1	WING KNOB	1/4-20 SOCKET HEAD CAP SCREW WING NUT

ELITE INDUSTRIAL SALES | TSM-1501M FACING/SQUARING MACHINE

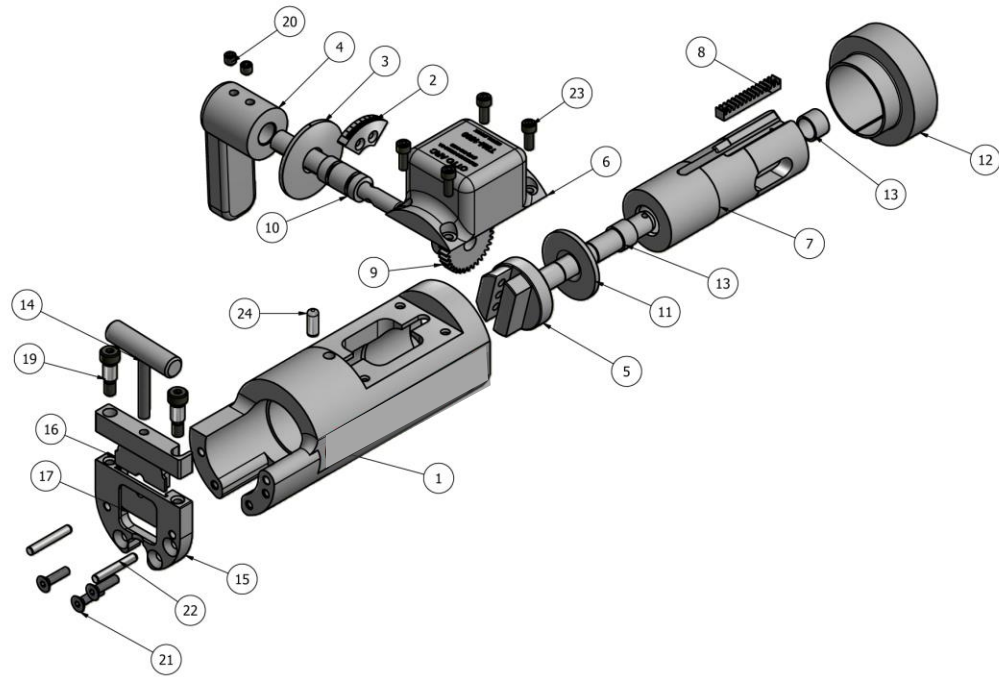

PARTS LIST			
ITEM	QTY	PART NUMBER	DESCRIPTION
1	1	TSM-201M-1	MAIN BODY
2	1	TSM-360	INDEX FEED
3	1	TSM-361	FEED DIAL
4	1	TSM-4615	SHIFT LEVER
5	1	TSM-200M	CUTTER SHAFT
6	1	TSM-203	GEAR HOUSING
7	1	TSM-204	INSIDE BODY
8	1	TSM-209	RACK
9	1	TSM-210	GEAR
10	1	TSM-216L-B	HANDLE FEED
11	1	TSM-224	THRUST WASHER
12	1	TSM-254	METABO DRILL MOTOR ADAPTER
13	2	TSM-212	BEARING
14	1	TSM-298	KNOB WITH SCREW
15	1	TSM-293	CLAMP BODY
16	1	LOWER COLLET	250-LOWER JAW
17	1	UPPER COLLET	250-UPPER JAW
18	1	TSM-291	CLAMP LATCH
19	2	TSM-294	5/16X1/2" SOCKET HEAD ShoulderBolt
20	2		SetScrew 1/4-20 UNCX0.25"
21	3		10/32X3/4" FLAT HEAD CAP SCREW
22	2		DOWEL PIN 0.1875"x1.25"
23	4		SHCS - 10/32X1/2"
24	1		DOWER PIN

TSM-1501M BENCH MOUNT VIEW

